

# Expansion Tanks

## Series ETX, ETSX

### Pressurized Expansion Tanks for Heating and Cooling Systems\*

Series ETX and ETSX Pressurized Expansion Tanks for Heating and Cooling Systems are designed to absorb the increased volume of water created when water is heated. These tanks maintain system pressure below the relief setting of the relief valve. The Series ETX and ETSX's pre-pressurized steel tank features a durable expansion membrane that prevents contact of the water with the air in the tank. This rugged diaphragm minimizes loss of the air change and ensures long and trouble-free life for the system.

#### Features

- Precharged at 12psi (82.7 kPa)
- Rugged flexible butyl diaphragm
- In-line and free standing models
- Compatible with glycol in systems
- Steel construction

#### Models

ETX      Mounts to supply piping

ETSX     Free standing

#### Specifications

Furnish and install as shown on plans a Watts Model ETX, ETSX \_\_\_\_ gallon \_\_\_\_ " diameter x \_\_\_\_ " (high) pre-charged steel expansion tank with a fixed butyl bladder. The tank shall have an NPT system connection and a .302"-32 charging valve connection (standard tire valve) to facilitate the on-site charging of the tank to meet system requirements. The tank shall be factory precharged to 12psi. The tank shall be a Watts Regulator Company Series ETX or ETSX.

**Maximum Working Temperature:** 220°F (104°C)

**Maximum Working Pressure:**

ETX-15, ETX-30, ETX-60: 75psi (517 kPa)

ETX-90 and ETSX Series: 100psi (6.89 bar)

Precharge (field adjustable): 12psi (82.7 kPa)

\*Not for use on potable water systems.



ETX



ETSX

# Expansion Tanks

Quick Sizing Chart				
Boiler Output Net BTU/H	Finned Tube Baseboard	Convectors or Unit Heaters	Cast Iron Radiators	Cast Iron Baseboard
<b>Suggested Selection</b>				
20,000	ETX-15	ETX-15	ETX-15	ETX-15
30,000	ETX-15	ETX-15	ETX-15	ETX-15
40,000	ETX-15	ETX-30	ETX-30	ETX-30
50,000	ETX-15	ETX-30	ETX-30	ETX-30
60,000	ETX-30	ETX-30	ETX-60	ETX-60
70,000	ETX-30	ETX-30	ETX-60	ETX-60
80,000	ETX-30	ETX-30	ETX-60	ETX-60
90,000	ETX-30	ETX-30	ETX-60	ETX-60
100,000	ETX-30	ETX-60	ETX-60	ETX-60
125,000	ETX-30	ETX-60	ETX-60	ETX-90
150,000	ETX-30	ETX-60	ETX-90	ETX-90
175,000	ETX-60	ETX-60	ETX-90	ETX-90
200,000	ETX-60	ETX-60	ETX-90	ETX-90
250,000	ETSX-30	ETSX-30	ETSX-40	ETSX-30
300,000	ETSX-30	ETSX-40	ETSX-40	ETSX-30
350,000	ETSX-30	ETSX-40	ETSX-60	ETSX-30
400,000	ETSX-30	ETSX-60	ETSX-90	ETSX-40
500,000	ETSX-40	ETSX-60	ETSX-90	ETSX-40
600,000	ETSX-40	ETSX-90	ETSX-90	ETSX-60
700,000	ETSX-60	ETSX-90	ETSX-90	ETSX-60
800,000	ETSX-60	ETSX-110	ETSX-110	ETSX-90
900,000	ETSX-60	ETSX-110	ETSX-110	ETSX-90
1,000,000	ETSX-90	ETSX-110	ETSX-110	ETSX-90
1,200,000	ETSX-90	ETSX-110	ETSX-160	ETSX-90
1,400,000	ETSX-110	ETSX-160	ETSX-160	ETSX-110
1,500,000	ETSX-110	ETSX-160	ETSX-110 (2)	ETSX-110

**Note:** These recommendations are based on the average water volume of typical closed systems.

Fill pressure 12psi, relief valve set pressure of 30psi and system temperature of 200°F.

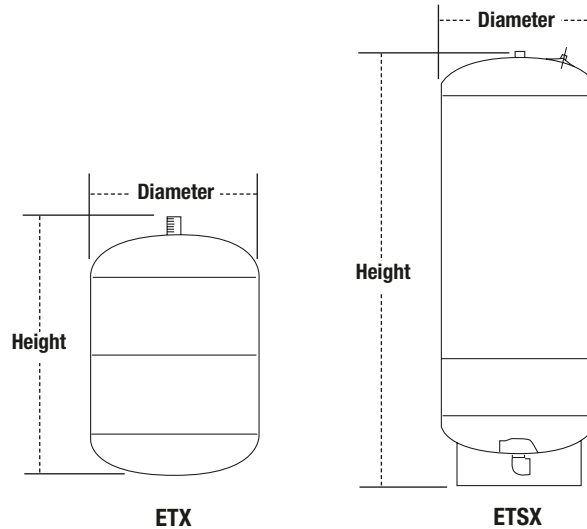

MODEL	CONNECTION SIZE (DN)		TANK VOLUME		ACCEPT. VOLUME		DIAMETER		HEIGHT		WEIGHT	
	in.	mm	gal.	liters	gal.	liters	in	mm.	in	mm.	lbs.	kgs.
ETX-15	½" MNPT	15	2.1	7.9	1.0	3.8	8	203	12½	318	5	2.3
ETX-30	½" MNPT	15	4.5	17.1	2.5	9.5	11	279	14	356	10.0	4.54
ETX-60	½" MNPT	15	6.0	22.8	3.0	11.4	11⅜	290	17⅜	437	11.5	5.22
ETX-90	¾" MNPT	20	15.0	57.0	6.0	22.8	16	406	20⅜	528	28.0	12.70
ETSX-30	1" FNPT	25	15.0	57.0	6.0	22.8	16	406	21⅜	551	32.0	14.51
ETSX-40	1" FNPT	25	20.0	76.0	8.0	30.4	16	406	28⅜	732	39.0	17.69
ETSX-60	1" FNPT	25	33.0	125.4	13.3	50.5	16	406	42⅜	1087	57.0	28.85
ETSX-90	1¼" FNPT	32	44.0	167.2	17.7	67.3	21	533	36⅜	919	72.0	32.66
ETSX-110	1¼" FNPT	32	62.0	235.6	24.9	94.6	21	533	47⅜	1217	112.0	50.80
ETSX-160	1¼" FNPT	32	81.0	307.8	32.6	123.9	21	533	62	1575	123.0	55.79